

ONE TECHNOLOGY PLACE – HOMER, NEW YORK 13077

TEL: +1 607 749 2000 FAX: +1 607 749 3295 www.PanavisionSVI.com sales@PanavisionSVI.com

Line Scan Image Sensor Demonstration Kit

For: LIS-1024, LIS-500, RPLIS-2048, ELIS-1024, and SLIS-2048

Key Features:

- **Demonstrates all capabilities of our image sensors**
- **USB 1.1 Interface – can connect to most PCs**
- **Flexible System Design**
 - 12 bit A/D to digitize the sensor analog output
 - 12 bit DACs to adjust ADC range and offset
 - Hardware and software triggers or free-run mode for frame capture
 - Dual board set
 - Motherboard contains FPGA, USB interface, JTAG, RS-232 (for debug), General Purpose I/O, debug LEDs, power, etc.
 - Sensor Daughterboard contains selected sensor and sensor related hardware, ADC, DACs, etc. Also contains user configurable filtering to allow user to optimize sensor performance at the selected operating speed and/or for a particular application.
- **Graphical User Interface and drivers included:**
 - Display ‘Oscilloscope’ graphs of pixel data
 - Capture, display, store, and retrieve 2D bitmap images up to 500 lines vertically
 - Enables user to select operating modes of sensor – control readout mode, gain, threshold, hysteresis, etc. where applicable for the installed sensor.
 - Control kit operating parameters
- **Programmable FPGA**
 - JTAG port enables user to modify FPGA code
- **Lens Mount**
 - All Daughterboards are supplied with a lens mount.
 - Supplied lens mount accepts M12 x 0.5P ½” optical format lenses except SLIS-2048 which accepts 1” format ‘CS’ lens.
- **Source Code**
 - Selected FPGA and GUI source code¹ and full schematics provided
- **Complete System**
 - Includes software, drivers, USB cable, and universal power supply[†]
 - [†]May require power adaptor for international power receptacles.

LIS-500 demo

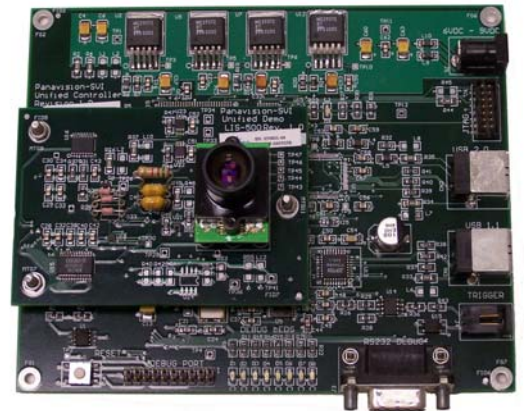

¹ Selected Source code modules provided. Software tools not provided. Modification of FPGA code may require 3rd party IP licensing – refer the full Line Scan Image Sensor Demonstration specification for details.

DESCRIPTIVE OVERVIEW:

The line scan demonstration kit is a complete image sensor control and acquisition system configured as a USB 'board' camera. It is configured as a two board system, a motherboard and a sensor specific daughterboard. Daughterboards are interchangeable. The system can capture up to 500 lines of data and then sends the data to the user's PC via the USB interface. The provided graphical user interface can display video waveforms on the PC monitor much like an oscilloscope or the kit can capture and display 2D bitmap grey scale images up to 500 lines high. Images can be stored, retrieved, and displayed and are saved in standard .bmp image format which can be further analyzed by the user. Oscilloscope traces can also be saved, the data points are saved to a .txt file which can be imported into most application programs for further analysis.

SIMPLIFIED BLOCK DIAGRAM

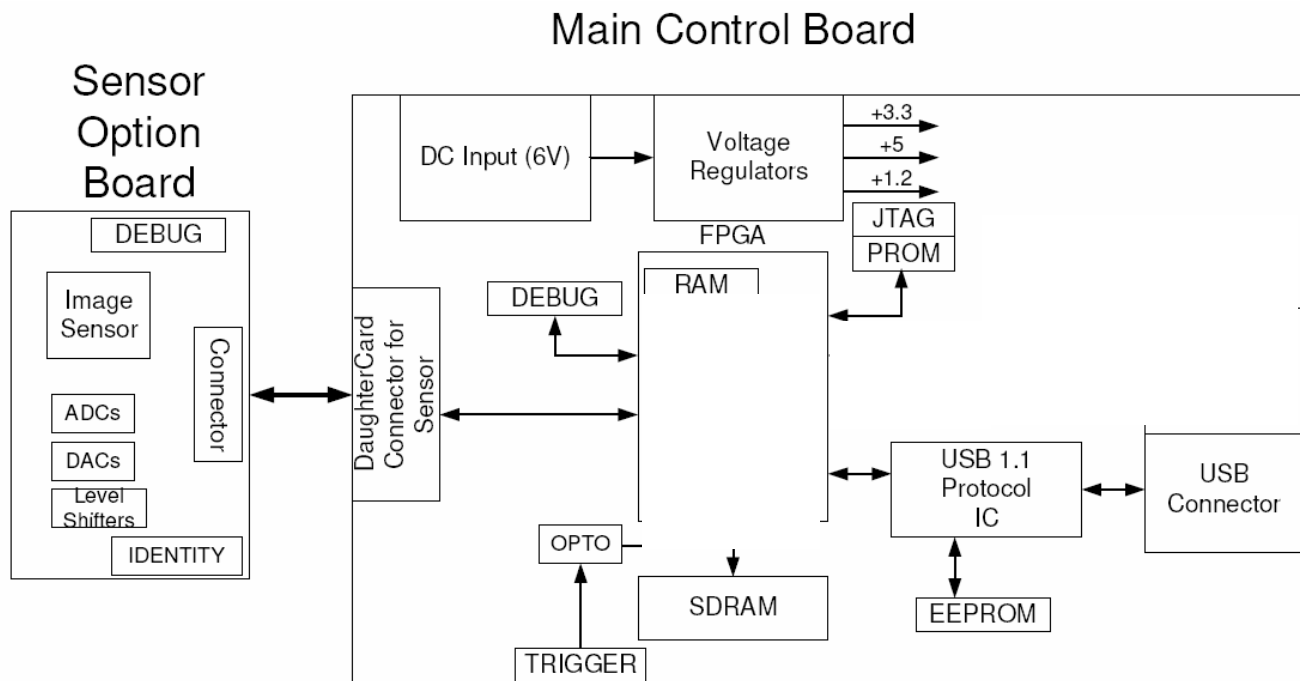

SYSTEM REQUIREMENTS:

Pentium III or better with 64k or more RAM running Windows® XP, NT, or 2000 operating system, CD drive, and XGA or better color monitor.

Power: 100 – 240 VAC, 50 – 60Hz, 0.3 Amps

Ordering information:

Motherboard - P/N DBD00003-A – includes power supply and software

LIS-1024 Daughtercard – P/N ADC-LIS-1024A

ELIS-1024 Daughtercard – P/N ADC-ELIS-1024A

LIS-500 Daughtercard – P/N ADC-LIS-500A

RPLIS-2048 Daughtercard – P/N ADC-RPLIS-2048A

SLIS-2048 Daughtercard – P/N ADC-SLIS-2048A

Daughtercards come with standard M12x0.5P lens mount.

Optional Lens* : 16mm focal length – M16X0.5P ; 25mm focal length – M25X0.5P

*Not for SLIS daughtercard. SLIS daughtercard accepts standard ‘CS’ style lenses, not supplied

ORDERING INFORMATION:

Complete Part number is DBD-0003A + ADC-XXXXX, where XXXX is the desired daughterboard.

For example, to order an SLIS-2048 demo kit the complete part number is DBD-0003A + ADC-SLIS-2048A

Additional Daughterboards may be ordered. Just specify the part number for the board as shown on page 2.

All Daughterboards are supplied with a lens mount. All Daughterboards except SLIS-2048 require ½” optical format lenses with M12 x 0.5P barrel for best performance. SLIS-2048 requires 1” optical format ‘CS’ type lens.

FOR MORE INFORMATION CONTACT YOUR LOCAL DISTRIBUTOR OR DIRECT:

Panavision SVI, LLC, Tel: +1 607 749 2000 x225 Fax: +1 607 749 3295 email:
sales@PanavisionSVI.com

*Windows is a registered trademark of Microsoft Corporation in the United States and other countries.
Panavision and the Panavision logo are registered trademarks of Panavision International, LP.*